

Specifications

EP16NT
EP18NT
EP20NT

CAT® Lift
Trucks



Electric powered lift trucks
3 wheel 48V, 1.6 - 2.0 tonnes

Characteristics			Cat Lift Trucks	Cat Lift Trucks	Cat Lift Trucks
1.01	Manufacturer (abbreviation)		EP16NT	EP18NT	EP20NT
1.02	Manufacturer's model designation		Electric	Electric	Electric
1.03	Power source: (battery, diesel, LP gas, petrol)		Seated	Seated	Seated
1.04	Operator type: pedestrian, (operator)-standing, -seated		Q (kg)	1.600	1.800
1.05	Load capacity	c (mm)	500	500	500
1.06	At load centre	x (mm)	376	376	387
1.08	Load distance	y (mm)	1307	1410	1410
1.09	Wheelbase				
Weight					
2.01	Truck weight, without load / including battery (simplex mast, lowest lift height)	kg	3090	3290	3520
2.02	Axle loading with maximum load, front/rear (simplex mast, lowest lift height)	kg	4175/515	4500/590	4870/650
2.03	Axle loading without load, front/rear (simplex mast, lowest lift height)	kg	1500/1590	1590/1700	1610/1910
Wheels, Drive Train					
3.01	Tyre type: V=solid, L=pneumatic, SE=solid pneumatic - front/rear		SE / SE	SE / SE	SE / SE
3.02	Tyre dimensions, front		18 x 7-8	18 x 7-8	200 / 50-10
3.03	Tyre dimensions, rear		15 x 4,5-8	15 x 4,5-8	140 / 55 - 9
3.05	Number of wheels, front/rear (x=driven)		2x / 2	2x / 2	2x / 2
3.06	Track width (centre of tyres), front	b10 (mm)	913	913	935
3.07	Track width (centre of tyres), rear	b11 (mm)	170	170	170
Dimensions					
4.01	Mast tilt, forwards/backwards	α/β °	6° / 7°	6° / 7°	6° / 7°
4.02	Height with mast lowered (see tables)	h1 (mm)	2105	2105	2105
4.03	Free lift (see tables)	h2 (mm)	80	80	80
4.04	Lift height (see tables)	h3 (mm)	3265	3265	3265
4.05	Overall height with mast raised	h4 (mm)	4332	4332	4332
4.07	Height to top of overhead guard	h6 (mm)	2048	2048	2048
4.08	Seat height	h7 (mm)	973	973	973
4.12	Tow coupling height	h10 (mm)	420	420	420
4.19	Overall length	l1 (mm)	2813	2916	2952
4.20	Length to fork face (includes fork thickness)	l2 (mm)	1893	1996	2032
4.21	Overall width	b1/b2 (mm)	1070	1070	1130
4.22	Fork dimensions (thickness, width, length)	s / e / l (mm)	35X100X920	35X100X920	35X100X920
4.23	Fork carriage to DIN 15 173 A/B/no		2A	2A	2A
4.24	Fork carriage width	b3 (mm)	920	920	920
4.31	Ground clearance under mast, with load	m1 (mm)	75	75	75
4.32	Ground clearance at centre of wheelbase, with load (forks lowered)	m2 (mm)	100	100	100
4.33	Working aisle width with 1000 x1200 mm pallets, crosswise	Ast (mm)	3218	3321	3356
4.34	Working aisle width with 800 x1200 mm pallets, crosswise	Ast (mm)	3037	3140	3175
4.35	Turning circle radius	Wa (mm)	1517	1620	1645
4.36	Minimum distance between centres of rotation	b13 (mm)	0	0	0
Performance					
5.01	Travel speed, with/without load	km/h	17/17	17/17	17/17
5.02	Lifting speed, with/without load	m/s	0.5/0.6	0.44/0.6	0.4/0.6
5.03	Lowering speed, with/without load	m/s	0.52/0.5	0.52/0.5	0.52/0.5
5.05	Rated drawbar pull, with/without load	N	4920/5390	4800/5330	4680/5270
5.06	Maximum drawbar pull, with/without load (5 min short duty)	N	13740/14210	13620/14150	13500/14080
5.07	Gradeability, with/without load	%	13/22	13/22	13/22
5.08	Maximum gradeability, with/without load	%	27/35	25/35	23/35
5.09	Acceleration time (10 metres) with/without load	s	4.4/4.0	4.4/4.0	4.5/4.1
5.10	Service brakes (mechanical/hydraulic/electric/pneumatic)		Mech./hydr.	Mech./hydr.	Mech./hydr.
Electric motors					
6.01	Drive motor capacity (60 min. short duty)	kW	5.0X2	5.0X2	5.0X2
6.02	Lift motor output at 15% duty factor	kW	14	14	14
6.03	Battery to DIN 43 531/35/36 A/B/C/no		-	-	-
6.04	Battery voltage/capacity at 5-hour discharge	V /Ah	48 V 600Ah	48V 720Ah	48V 720Ah
6.05	Battery weight	kg	865	1000	1000
6.06	Energy consumption according to VDI cycle	kWh/h	-	-	-
Miscellaneous					
8.01	Type of drive control		Impulse /AC	Impulse /AC	Impulse /AC
8.02	Maximum operating pressure for attachments	bar	181	181	181
8.03	Oil flow for attachments	l/min	-	-	-
8.04	Noise level, mean value at operator's ear	dB(A)	69.1	69.1	69.1
8.05	Towing coupling design / DIN type, ref.				

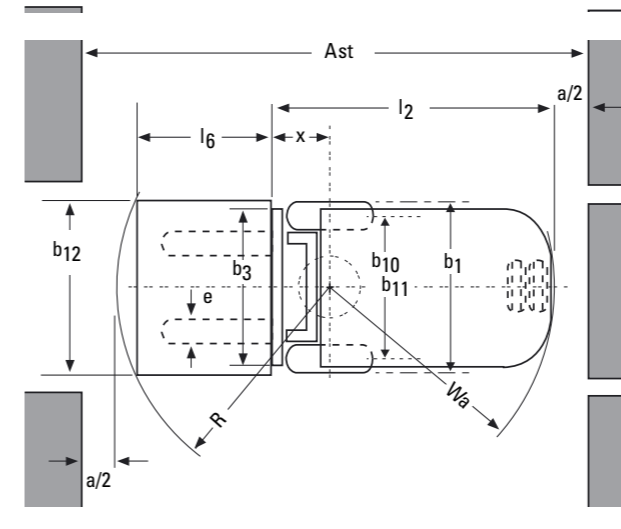
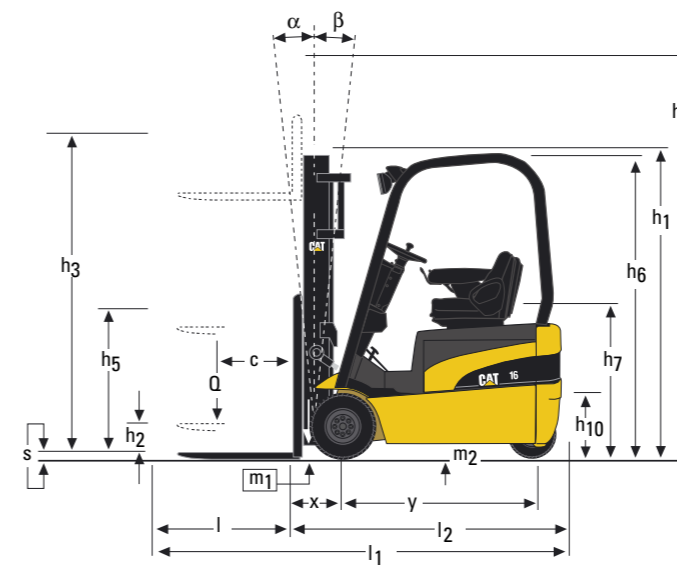

$$Ast = Wa + R + a$$

Ast = Working aisle width
 Wa = Turning radius
 a = Safety clearance = 2 x 100 mm
 $R = \sqrt{(l6 + x)^2 + (b12 / 2)^2}$
 l6 = Pallet length (800 or 1000 mm)
 b12 = Pallet width (1200 mm)

The EP16-20NT range - compact, productive and efficient...

Low Cost of Ownership

- Proven front wheel drive system for outstanding reliability.
- Advanced AC technology provides faster lift and travel speeds for quicker work cycles.
- New generation MicroCommand® AC controller provides optimum performance and energy efficiency.
- Profile tubed overhead guard allows simple application of panel cabins.

Operator Comfort

- Automotive pedal layout for easy operation.
- Adjustable armrest with fingertip controls for precise load handling.
- Full hydrostatic steering system for effortless manoeuvrability.
- Fully adjustable suspension seat.
- Tilttable steering column.
- Open step frame on each side of the truck allows easy entry and exit from either side if required.
- Compact dimensions ensure manoeuvrability in confined areas.

Service and Maintenance

- 500 hours service intervals for maximum 'up time'.
- Easy access to all components.
- Programmable diagnostics and performance via the display and PDA or Laptop.
- Heavy duty chassis and rigid mast.
- Strong regenerative braking speeds up working cycles, extends battery life and reduces brake wear.

Safety

- High visibility mast and overhead guard.
- Presence detection System (PDS) prevents operation while driver not seated.
- Backup alarm supplied as standard.

Options

- Strobe Light.



Cat® Lift Trucks.

Your partner in materials handling.

Mast type	EP16NT/EP18NT/EP20NT				EP16NT	EP18NT	EP20NT
	h3 mm	h1 mm	h4 mm	h2 / h5 mm	Q @ c = 500 mm kg	Q @ c = 500 mm kg	Q @ c = 500 mm kg
Simplex	2000	1460	3045	80	1600	1800	2000
	2560	1740	3605	80	1600	1800	2000
	2760	1840	3805	80	1600	1800	2000
	3000	1960	4045	80	1600	1800	2000
	3290	2105	4335	80	1600	1800	2000
	3720	2365	4765	80	1600	1800	2000
	4090	2550	5135	80	1575	1800	2000
	4480	2755	5525	80	1525	1750	2000
	5000	3015	6045	80	1275	1300	1925
	5500	3265	6545	80	975	1100	1300
6000	3515	7045	80	850	875	1225	
Duplex	3000	1960	4045	915	1600	1800	2000
	3295	2105	4340	1060	1600	1800	2000
	3700	2365	4745	1320	1600	1800	2000
	4030	2550	5075	1505	1575	1800	2000
Triplex	3710	1760	4755	715	1600	1800	2000
	4010	1860	5055	815	1575	1800	2000
	4310	1960	5355	915	1550	1800	2000
	4750	2105	5795	1060	1375	1425	1950
	5090	2225	6135	1180	1375	1425	1800
	5490	2365	6535	1320	1025	1075	1300
	5990	2550	7035	1505	775	800	1225
	6490	2810	7535	1765	675	675	875
	7000	3015	8045	1970	475	500	775

(Consult your dealer for the maximum back tilt allowed, to obtain the capacities specified)

Mast Performance and Capacity

- h1 Height with mast lowered
- h2 Standard free lift
- h3 Lift height
- h4 Height with mast raised
- h5 Full free lift
- Q Lifting capacity, rated load
- c Load centre (distance)

Battery Compartment	EP16NT	EP18NT	EP20NT
Length (min) mm	531	634	634
Width (min) mm	1016	1016	1016
Height (min) mm	650	650	650
Minimum weight kg	865	1000	1000

Capacities at various load centres

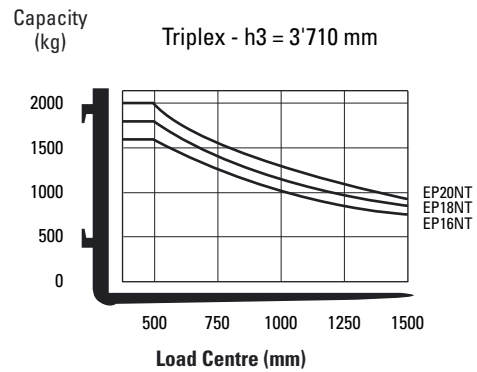
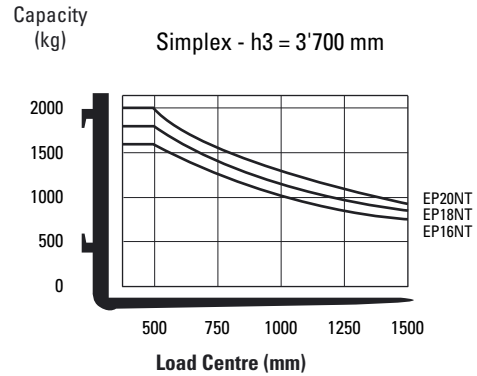

CATERPILLAR®

catliftruck@mcf.nl

www.catliftruck.com

CESC0701(10/05)ok

Copyright ©2005, MCFE. All rights reserved.

CAT, CATERPILLAR, their respective logos and 'Caterpillar Yellow', as well as corporate and product identity used herein, are trademarks of Caterpillar and may not be used without permission.

Printed in The Netherlands

NOTE: Performance specifications may vary depending on standard manufacturing tolerances, vehicle condition, types of tyres, floor or surface conditions, applications, or operating environment. Trucks may be shown with non-standard options. Specific performance requirements and locally available configurations should be discussed with your Cat Lift Trucks Dealer. Cat Lift Trucks follows a policy of continual product improvement. For this reason, some materials, options and specifications could change without notice.