

Specifications

EP40

EP45

EP50

CAT® Lift
Trucks



Electric powered lift trucks
4 Wheel 80V, 4.0 - 5.0 tonnes

Characteristics		Cat Lift Trucks	Cat Lift Trucks	Cat Lift Trucks	
		EP40	EP45	EP50	
1.01	Manufacturer (abbreviation)				
1.02	Manufacturer's model designation				
1.03	Power source: (battery, diesel, LP gas, petrol)	Electric	Electric	Electric	
1.04	Operator type: pedestrian, (operator)-standing, -seated	Seated	Seated	Seated	
1.05	Lifting capacity	Q (t)	4.0	4.5	4.99
1.06	At load centre	c (mm)	500	500	500
1.08	Load distance	x (mm)	510	510	510
1.09	Wheelbase	y (mm)	2000	2000	2000
Weight					
2.01	Truck weight, without load / including battery	kg	6600	6950	7300
2.02	Axle loading with rated load, front/rear	kg	9700 / 900	10400 / 1050	11200 / 1100
2.03	Axle loading without load, front/rear	kg	3700 / 2900	3700 / 3250	3700 / 3600
Wheels, Drive Train					
3.01	Tyre type: V=solid, L=pneumatic, SE=solid pneumatic - front/rear		SE / SE	SE / SE	SE / SE
3.02	Tyre dimensions, front		250-15	250-15	28 x 12.5-15
3.03	Tyre dimensions, rear		21 x 8-9	21 x 8-9	21 x 8-9
3.05	Number of wheels, front/rear (x=driven)		2x / 2	2x / 2	2x / 2
3.06	Distance between centreline of tyres, front	b10 (mm)	1120	1120	1150
3.07	Distance between centreline of tyres, rear	b11 (mm)	950	950	950
Dimensions					
4.01	Mast tilt, forwards/backwards	∂/β °	6/8	6/8	6/8
4.02	Height with mast lowered	h1 (mm)	2405	2405	2405
4.03	Standard free lift	h2 (mm)	150	150	150
4.04	Standard lift height	h3 (mm)	3000	3000	3000
4.05	Overall height with mast raised	h4 (mm)	4398	4398	4248
4.07	Height to top of overhead guard	h6 (mm)	2320	2320	2320
4.08	Seat height	h7 (mm)	1165	1165	1165
4.12	Tow coupling height	h10 (mm)	390 / 550	390 / 550	390 / 550
4.19	Overall length	l1 (mm)	3980	3980	3980
4.20	Length to fork face (includes fork thickness)	l2 (mm)	2830	2830	2830
4.21	Overall width	b1/b2 (mm)	1340	1340	1450
4.22	Fork dimensions (thickness, width, length)	s / e / l (mm)	50x150x1150	60x150x1150	60x150x1150
4.23	Fork carriage to DIN 15 173 A/B/no		3A	3A	3A
4.24	Fork carriage width	b3 (mm)	1260	1260	1260
4.31	Ground clearance under mast, with load	m1 (mm)	120	120	120
4.32	Ground clearance centre of wheelbase, with load	m2 (mm)	160	160	160
4.33	Working aisle width with 1000 x1200 mm pallets	Ast (mm)	4160	4160	4160
4.34	Working aisle width with 800 x1200 mm pallets	Ast (mm)	4360	4360	4360
4.35	Turning circle radius	Wa (mm)	2450	2450	2450
4.36	Minimum distance between centres of rotation	b13 (mm)	670	670	670
Performance					
5.01	Travel speed, with/without load	km/h	15 / 17	15 / 16.5	15 / 16
5.02	Lifting speed, with/without load	m/s	0.35 / 0.47	0.33 / 0.45	0.31 / 0.45
5.03	Lowering speed, with/without load	m/s	0.55 / 0.50	0.55 / 0.50	0.55 / 0.50
5.05	Rated drawbar pull, with/without load (60 min short duty)	N	5100 / 5600	4900 / 5500	5000 / 5800
5.06	Maximum drawbar pull, with/without load (5 min short duty)	N	14600 / 14900	14500 / 14800	15100 / 15500
5.07	Gradeability, with/without load	%	8 / 13.5	7 / 12	6.5 / 12
5.08	Maximum gradeability, with/without load	%	14 / 23.5	12.5 / 21.5	12 / 21
5.09	Acceleration time, with/without load (0 -10 m)	s	5.0 / 4.4	5.5 / 4.8	5.8 / 5.2
5.10	Service brakes (mechanical/hydraulic/electric/pneumatic)		Hydraulic	Hydraulic	Hydraulic
Electric motors					
6.01	Drive motor capacity (60 min. short duty)	kW	18	18	18
6.02	Lift motor output @ 15% duty factor	kW	23.5	23.5	23.5
6.03	Battery to DIN 43 531/35/36 A/B/C/no		43536 A	43536 A	43536 A
6.04	Battery, voltage/capacity at 5-hour discharge	V / Ah	80 / 840	80 / 840	80 / 840
6.05	Battery, weight	kg	2178	2178	2178
6.06	Energy consumption according to VDI cycle	kWh/h	10.5	11	11.5
Miscellaneous					
8.01	Type of drive control		Impulse /AC	Impulse /AC	Impulse /AC
8.02	Operating pressure for attachments	bar	200	200	200
8.03	Oil flow for attachments	l/min	30	30	30
8.04	Noise level, mean value at operator's ear	dB(A)	75	75	75
8.05	Towing coupling design / DIN type, ref.		DIN 15170-H	DIN 15170-H	DIN 15170-H

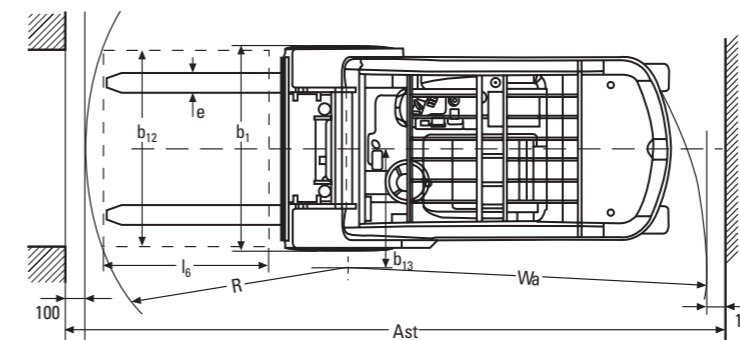
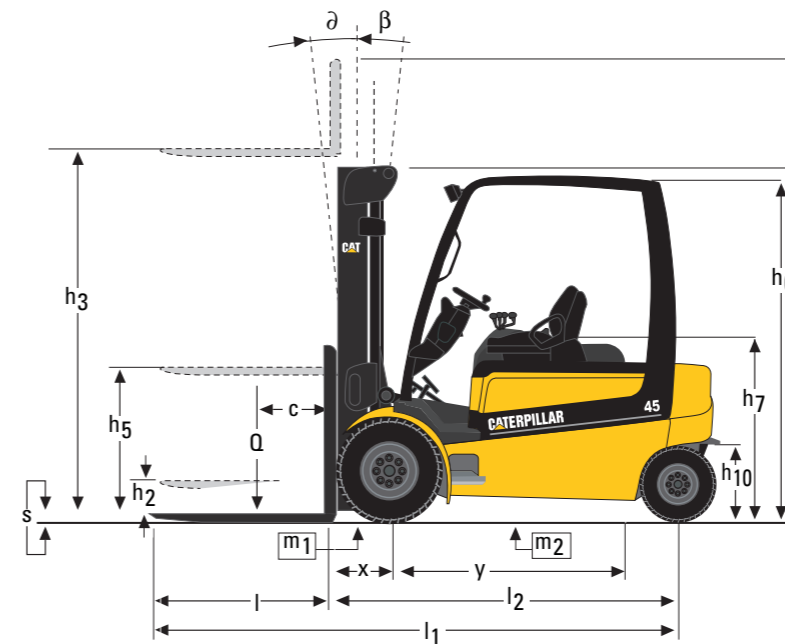

$$A_{st} = W_a + x + l_6 + a$$

- Ast = Working aisle width with load
- a = Safety clearance (200 mm)
- l6 = Pallet length (800 or 1000 mm)
- b12 = Pallet width (1200 mm)



Five application programmes can be individually tailored to ensure optimal performance in any application. The easy to use display provides a digital service meter, battery discharge indicator as well as lift cut out, clock, error code and warning displays.

The EP40-50 series provides performance and power suitable for any application...

Low Cost of Ownership

- Long maintenance intervals reduces the total cost of ownership.
- Maintenance free wet disc brakes and AC motors help to minimise service cost.
- Intelligent monitoring allows the operator to supervise all major truck functions during normal operation, helping to ensure that the truck is serviced as and when required.

Safety and Ergonomics

- Automatic speed reduction increases stability of the truck when cornering with a load.
- Automatically applied park brake and anti roll back function ensure that the truck is always parked safely, even on a ramp.
- Automotive pedal lay-out.
- Low step in chassis for easy on/off access.

Productivity

- The powerful AC based traction motor is sealed against dust and water splashes and features optimum torque for excellent acceleration, traction, speed and braking.
- Strong regenerative braking speeds up working cycles, extends battery life and reduces brake wear.
- Ideal for gradients and applications where the power of an IC engine truck is needed.

Options

- Factory fitted panel cabin.
- Integral side shifter.
- Additional working lights.



Cat® Lift Trucks.

Your partner in materials handling.

Mast type	EP40/EP45				EP40	EP45
	h3 mm	h1 mm	h4 mm	h2 / h5 mm	Q @ c = 500 mm kg	Q @ c = 500 mm kg
Simplex	2750	2280*	4148	150	4000	4500
	3000	2405	4398	150	4000	4500
	3500	2655	4898	150	4000	4500
	4000	2905	5398	150	4000	4500
	4500	3155	5898	150	4000	4500
	5000	3405	6398	150	4000	4500
	5500	3655	6898	150	3650	4100
	6000	3905	7398	150		
	6500	4155	7898	150		
Duplex	2950	2205*	4222	1500	4000	4500
	3450	2455	4722	1750	4000	4500
	3950	2705	5222	2000	4000	4500
	4450	2955	5722	2250	4000	4500
Triplex	3800	2080*	5072	1375	4000	4500
	4175	2205*	5447	1500	4000	4500
	4925	2455	6197	1750	3920	4420
	5300	2580	6572	1875	3890	4300
	5675	2705	6947	2000	3750	4200
	6425	2955	7697	2250	3580	3800
	7175	3205	8447	2500	2850	3200

Mast type	EP50				
	h3 mm	h1 mm	h4 mm	h2 / h5 mm	Q @ c = 500 mm kg
Simplex	2750	2280*	3998	150	4990
	3000	2405	4248	150	4990
	3500	2655	4748	150	4990
	4000	2905	5248	150	4990
	4500	3155	5748	150	4990
	5000	3405	6248	150	4750
	5500	3655	6748	150	4400
	6000	3905	7248	150	
	6500	4155	7748	150	
Duplex	2950	2205*	4222	1350	4990
	3450	2455	4722	1600	4990
	3950	2705	5222	1850	4990
	4450	2955	5722	2100	4990
Triplex	3800	2080*	5072	1225	4990
	4175	2205*	5447	1350	4800
	4925	2455	6197	1600	4750
	5300	2580	6572	1725	4700
	5675	2705	6947	1850	4610
	6425	2955	7697	2100	4100
	7175	3205	8447	2350	3500

* lower than overhead guard

Mast Performance and Capacity

- h1 Height with mast lowered
- h2 Standard free lift
- h3 Lift height
- h4 Height with mast raised
- h5 Full free lift
- Q Lifting capacity, rated load
- c Load centre (distance)

Battery Compartment		EP40	EP45	EP50
Length (min)	mm	1012	1012	1012
Width (min)	mm	1038	1038	1038
Height (min)	mm	840	840	840
Minimum weight (80V)	kg	2069	2069	2069



catliftruck@mcf.nl
www.catliftruck.com

CESC0714(07/05)ok
Copyright ©2005, MCFE. All rights reserved.
CATERPILLAR and CAT are registered trademarks of Caterpillar Inc.
Printed in The Netherlands

NOTE: Performance specifications may vary depending on standard manufacturing tolerances, vehicle condition, types of tyres, floor or surface conditions, applications, or operating environment. Trucks may be shown with non-standard options. Specific performance requirements and locally available configurations should be discussed with your Cat Lift Trucks Dealer. Cat Lift Trucks follows a policy of continual product improvement. For this reason, some materials, options and specifications could change without notice.